

# Advancing Solar's Environmental Benefits

## A Lifecycle Assessment

Tyler Williams  
GreenMountain Engineering



Sarah Boyd  
University of California, Berkeley

Tonio Buonassisi  
Lawrence Berkeley National Laboratory

- Examine technology and design options from feedstock to integration in order to identify opportunities to minimize the environmental impact of PV systems
- Why? Photovoltaics will be deployed on a massive worldwide scale with major environmental implications

1 GW



4000 GW

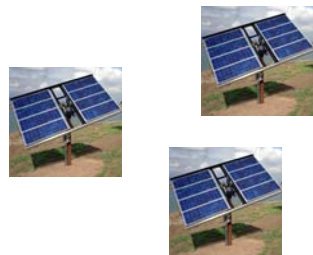

- **Confirms and quantifies the environmental benefits of photovoltaics**
- **Indicates that certain easily-implemented design and material choices are environmentally preferable to others**

## Traditional/ SETAC LCA

(Society of Environmental Toxicology and  
Chemistry)

## EIOLCA

(Economic Input-output)

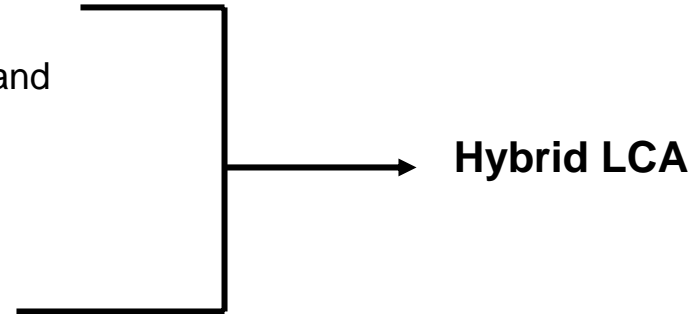

- What is LCA?

The evaluation of the environmental impacts of a product or process throughout its lifetime

- What is EIOLCA?

Resource requirements and environmental emissions required for a particular product or service are based on economic transactions and toxic release data

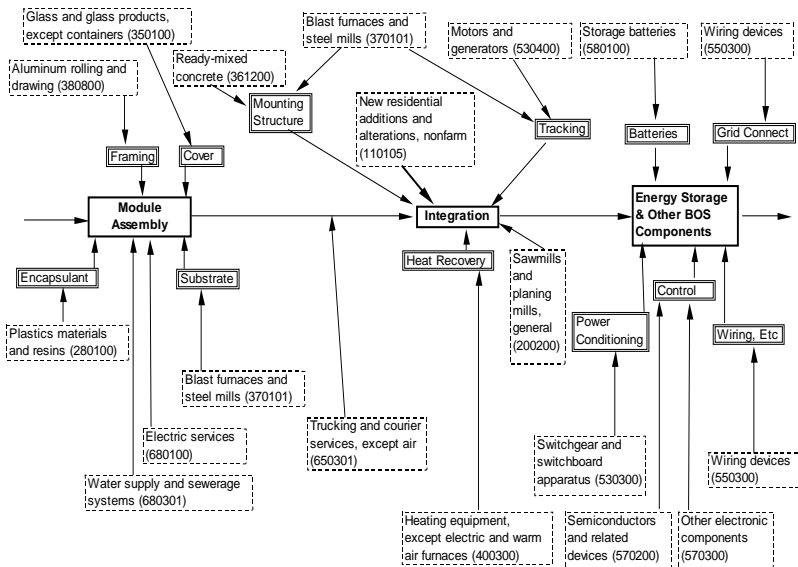

<b>Total Cost For 2.5kWp System</b>	<b>\$18,330</b>
<b>Total Economic Activity For All Sectors</b>	<b>\$38,109</b>
Semiconductors and related devices	\$12,346
New residential additions and alterations, nonfarm	\$3,790
Switchgear and switchboard apparatus	\$1,994
Wholesale trade	\$1,810
Other repair and maintenance construction	\$1,583
Blast furnaces and steel mills	\$1,005
Electric services (utilities)	\$991
Industrial inorganic and organic chemicals	\$689
Trucking and courier services, except air	\$504
...	...
Wiring devices	\$404
Advertising	\$359
...	...
Eating and drinking places	\$111
...	...
Colleges, universities, and professional schools	\$29

# Results 1: Societal Benefits

- **Reduces the amount of global-warming gas emissions (grams CO<sub>2</sub> equivalent) by a factor of six**
- **Reduces the environmental and social costs passed on to society by a factor of ten (“economic externalities”)**
- **Promotes three to five (3-5) times more new jobs per watt installed capacity**

# Results 2: Solar Manufacturing

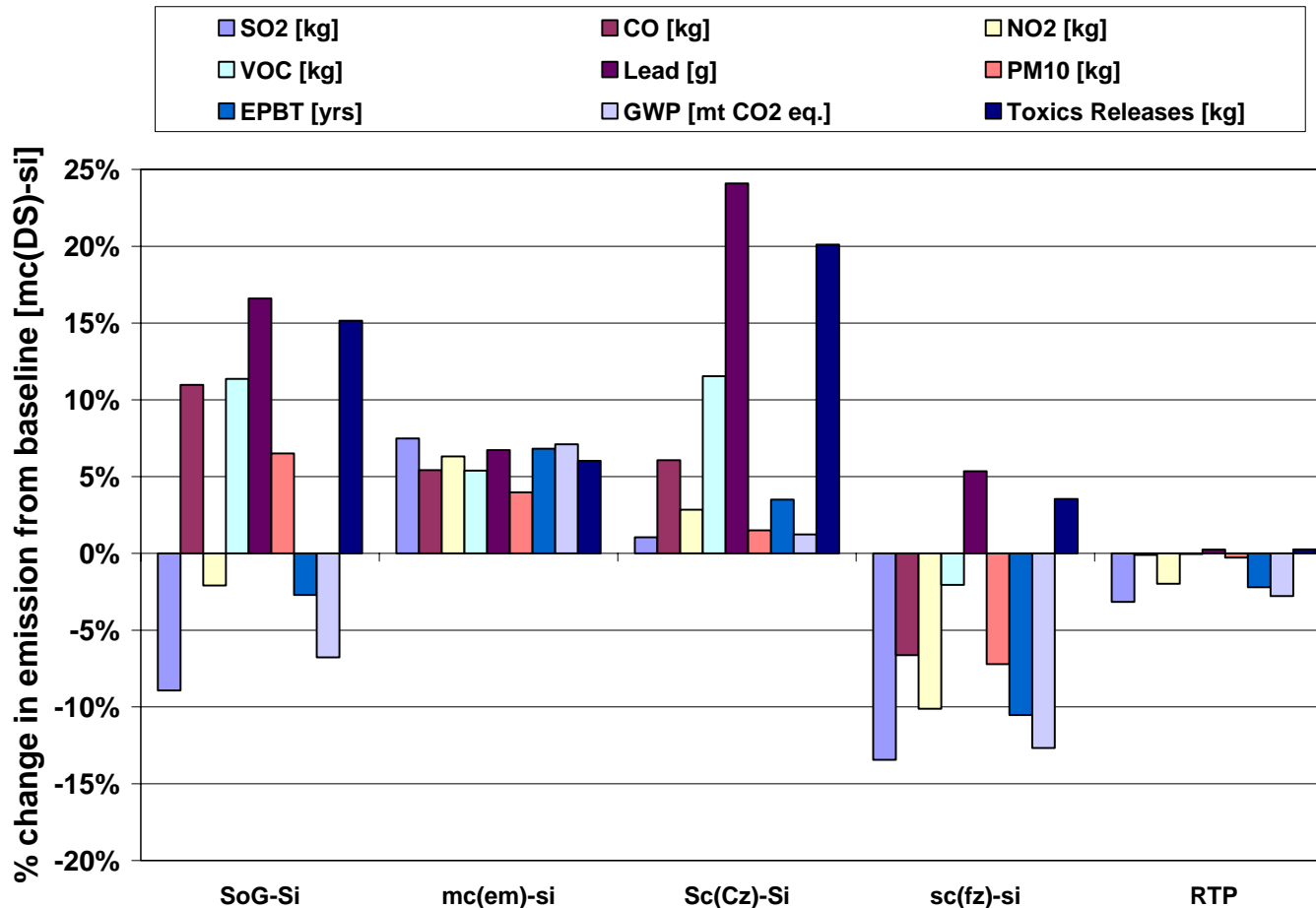

# Results 3: Installation

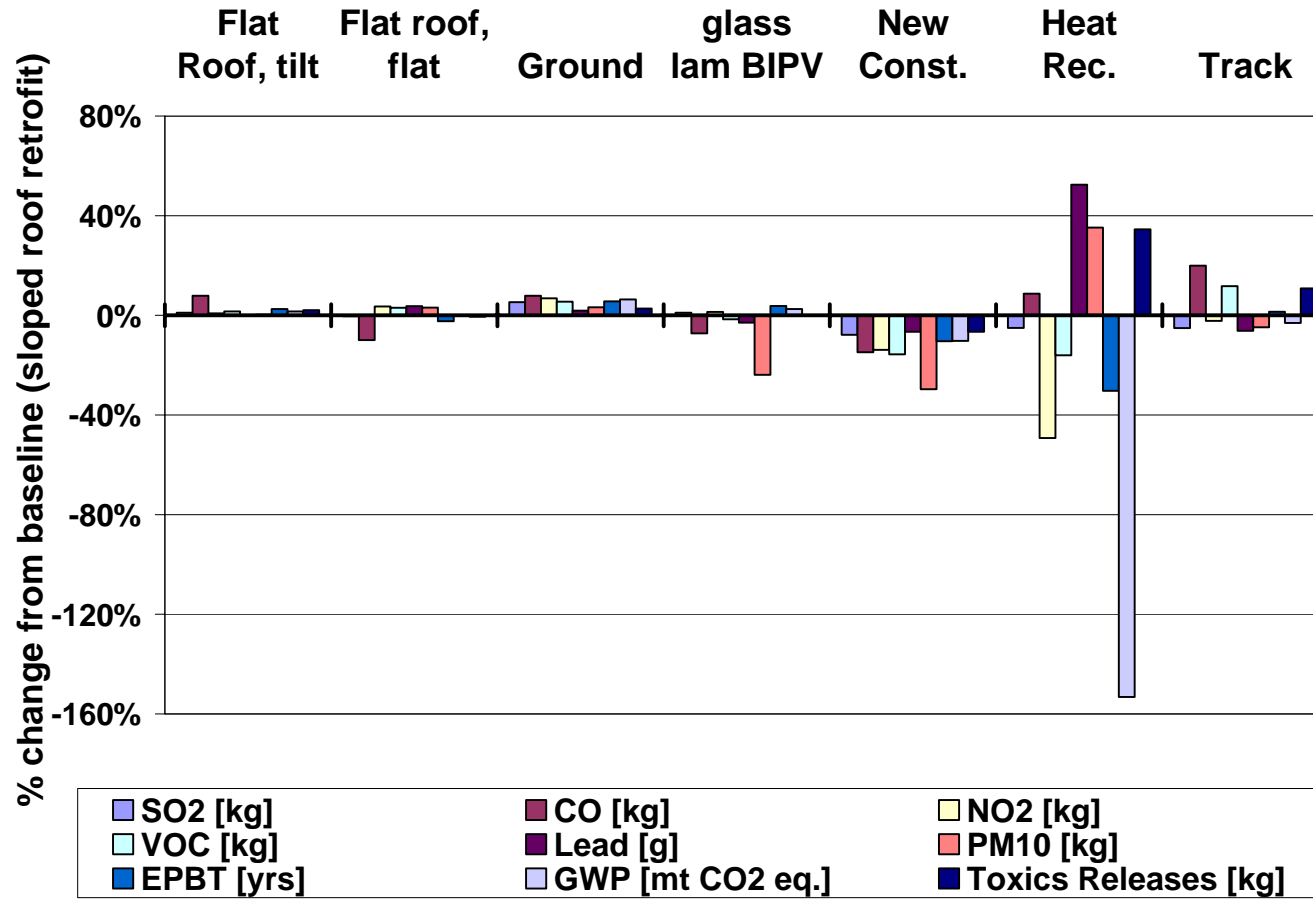

# Results 4: Supply Chain Management

**Weighted Toxic Release Breakdown By Economic Sector**

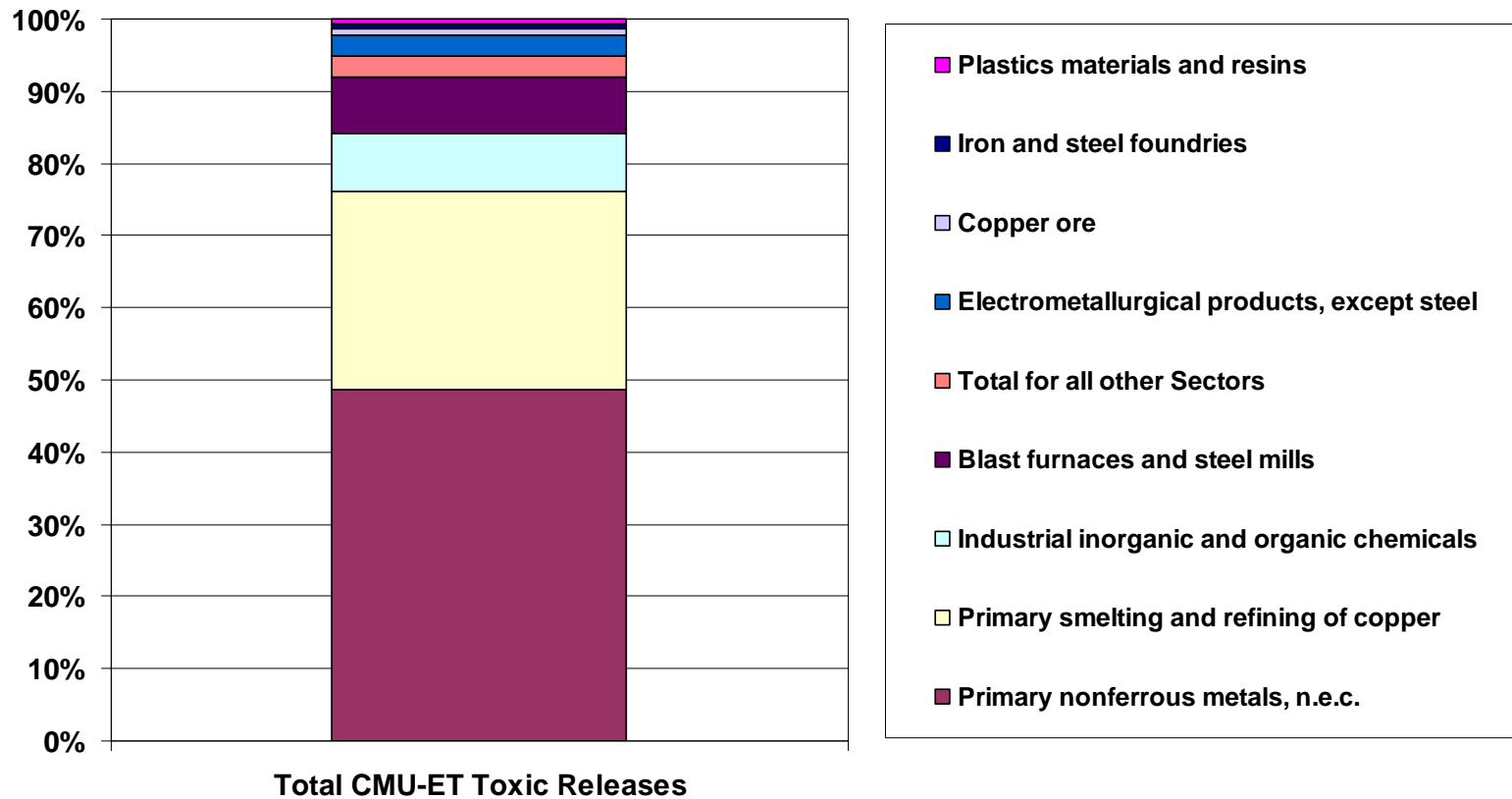

# Results: What Can You Do Now?

- Raw material: Solar-grade feedstock to reduce energy content
- Cell processing: Rapid thermal processing to reduce energy consumption
- Module manufacturing: Advanced encapsulants to extend life
- Integration and installation:
  - Grid connection to avoid batteries
  - Architectural integration using fixed, flat plate modules to minimize balance-of-system hardware
  - Solar as part of new construction to make installation more efficient
- Entire supply chain: Environmental Supply Chain Management



**Thank you!**

Tyler Williams

TylerW@GreenMountainEngineering.com